

Datasheet

# SATADOM-ML

## 3TG6-P series

- Built-in Pin 8 power supply
- Best boot drive solution for server and embedded system
- SATA 6Gb/s interface
- High IOPS to reduce boot up timing
- End to End data path protection
- Anti-vibration mechanical design
- Built in iData Guard
- Hardware write protection supported



## Introduction

Innodisk Serial ATA Disk on Module (SATADOM) supports SATA III standard (6.0Gb/s) interface with excellent performance, and SATADOM-ML 3TG6-P is designed as the smallest form factor size that could enhance compatibility with various design applications.

The innovative Pin8 uses the SATA connector itself as a power supply to drive the device without external cables. It could be connected directly to the SATA on-board socket on customers' system without additional power cable. Besides, the booting time for operation and the power consumption is less than hard disk drive (HDD), and can work under harsh environment compile with ATA protocol, no additional drives are required, and the SSD can be configured as a boot device or data storage device.

# SATADOM-ML

## 3TG6-P series

Contact us for more information about the SATADOM-ML 3TG6-P.

Innodisk is a service-driven provider of industrial embedded flash storage and Dram products and technologies, with a focus on the cloud computing, industrial/embedded, and aerospace and defense industries.

### Diagram

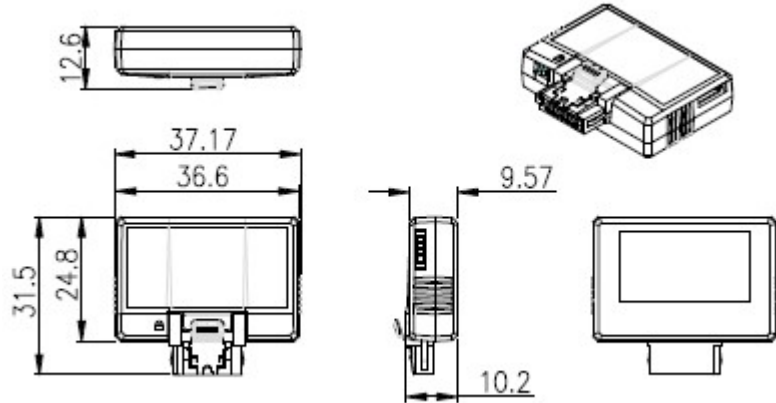

Dimension tolerance:  $\pm 0.2\text{mm}$

#### Headquarters (Taiwan)

5F., No. 237, Sec. 1, Datong Rd.,  
Xizhi Dist., New Taipei City,  
Taiwan (R.O.C.)  
Tel: +886-2-7703-3000  
Email: [sales@innodisk.com](mailto:sales@innodisk.com)

#### Branch Offices:

USA  
[usasales@innodisk.com](mailto:usasales@innodisk.com)  
+1-510-770-9421  
Europe  
[esusales@innodisk.com](mailto:esusales@innodisk.com)  
+31-(0)40-282-1818  
Japan  
[jpsales@innodisk.com](mailto:jpsales@innodisk.com)  
+81-3-6667-0161  
China  
[sales\\_cn@innodisk.com](mailto:sales_cn@innodisk.com)  
+86-755-21673689  
[www.innodisk.com](http://www.innodisk.com)

© 2018 Innodisk Corporation.  
All right reserved. Specifications  
are subject to change without  
prior notice.

### Specifications

Interface	SATA III
Flash Type	3D TLC
Capacity	128GB~256GB
Max. Channels	4
Sequential R/W (MB/sec, max.)	560/90
Max. Power Consumption	2.14W (5V x 428mA )
Thermal Sensor	√
Extended DRAM buffer	√
H/W Write Protect	√
ATA Security	√
S.M.A.R.T.	√
Dimension (WxLxH)	37.17 x 31.5 x 10.2 mm
Environment	Vibration: 20G @7~2000Hz Shock: 1500G @ 0.5ms Storage Temperature: -55°C ~ +95°C MTBF: 3 million hours

20181122

### Ordering Information

	128GB	256GB
Standard Grade (0°C ~ +70°C)	DGSML- A28M71ECAQF*	DGSML- B56M71ECAQF*
Industrial Grade (-40°C ~ +85°C)	DGSML- A28M71EWAQF*	DGSML- B56M71EWAQF *

\* = A: Pin8+ power cable

\* = B: Pin8+ Pin 7