

AX710-XAV-FN70

Features

- Active FAN solution.
- It supports various I/O ports, to provide better platform for the users to develop application.
- Specifically designed for high performance and flexibility develop AI computing.
- Extended temperature range -25°C to 80°C.
- Suitable for general robotics, UAV, industrial inspection, medical imaging and deep learning.

Specifications

System Carrier Board

- AX710

Module

- NVIDIA® Jetson AGX Xavier™

Material

- SECC

Chassis Color

- Black

Standard I/O

- Power Button
- 2x HDMI Type A
- 3x RJ-45 for GbE
- 2x USB3.2 Gen1 Type A
- 1x USB2.0 AB OTG
- 1x USB Type C (USB 2.0 speed)
- 2x CAN BUS
- 2x COM port (1x RS-232 / 2 x UART / 1 x I2C / 5 x GPIO)
- 1x Micro SD

Power Supply

- 6pin Power Connector DC-in 9V~20V

Dimension

- 124(W) x 118(D) x 96(H)mm

Operating Temperature

- -25°C ~ +80°C

Operating Humidity

- 10% ~ 95%

Storage Temperature

- -40°C ~ +85°C



Block Diagram

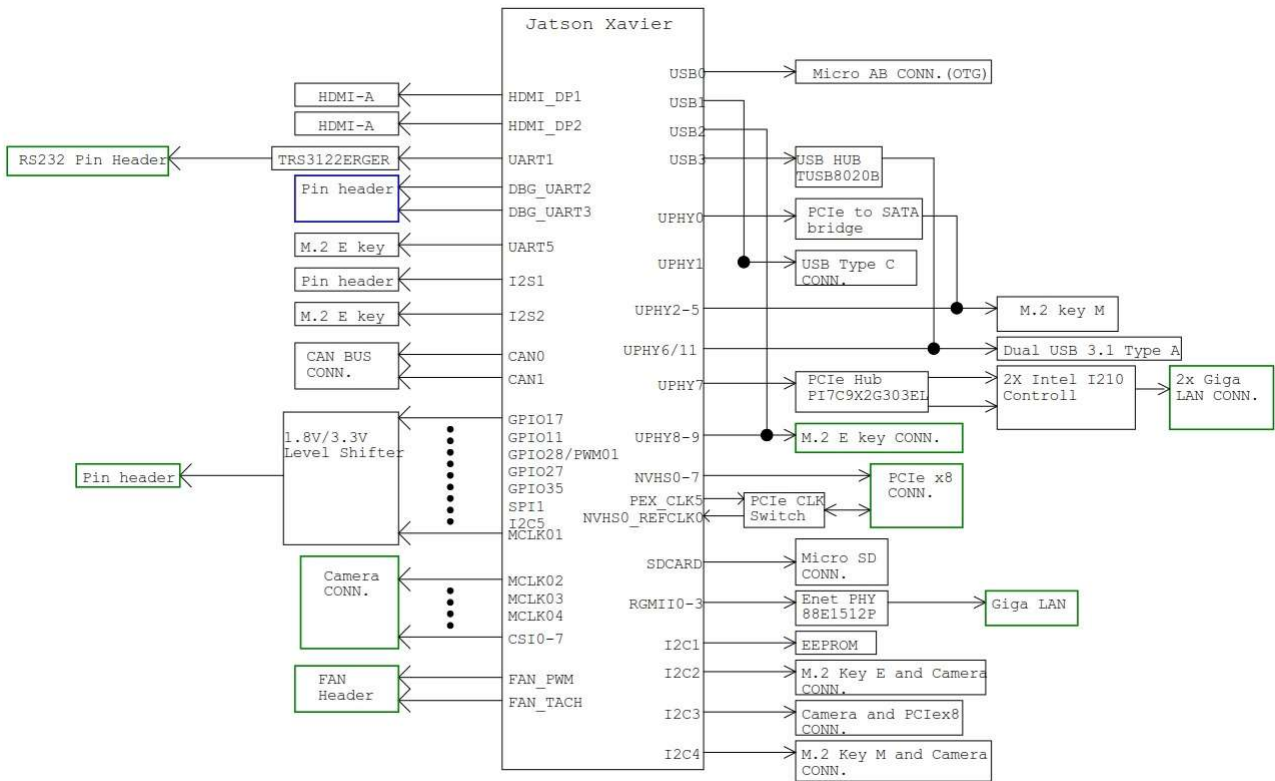

Dimension

